

UL LISTED FIRE FOAM MONITOR

MODEL GGT SGR 1000

1. GENERAL DESCRIPTION

The manually operated self-inducting non-aspirating Compact Foam Monitor fully made of Stainless Steel, capable of discharging 1000 US GPM (3785 LPM) at 100 psi inlet pressure over a range of 65 to 70 meters in horizontal direction. Foam proportioning 3 % is done with help of Foam Inductor placed within the Nozzle. The Foam Monitor has facility for converting Water / Foam jet to fog and vice-versa very quickly and easily, even during continuous operation. Foam Monitor is provided with self-locking swivel gear bearing for rotation in horizontal and vertical direction through hand wheel operation even under high operating pressures. A single fire fighter can manually operate the Foam Monitor with large flow & long-range capability. The monitor assembly is designed to withstand the nozzle reaction force experienced during the operation of jet / fog.

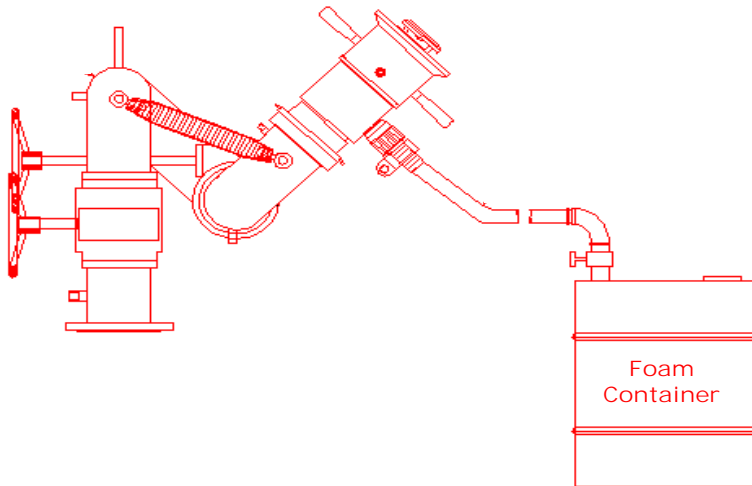
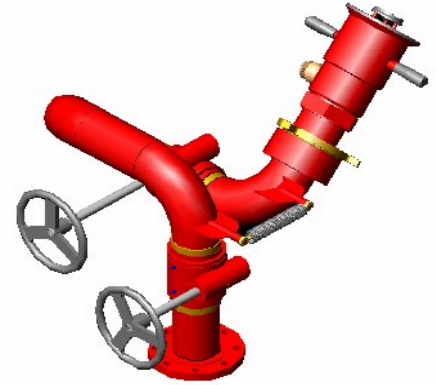

Jet & Fog Adjustment

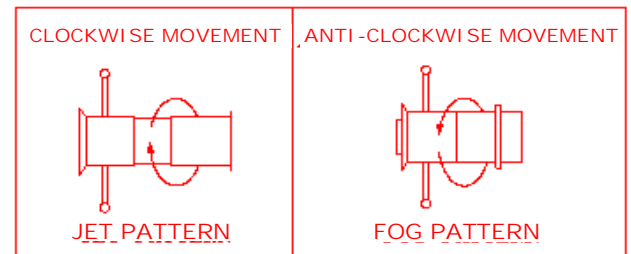

2. SALIENT FEATURES

- ✚ Certified and Approved by **(UL) Underwriters Laboratory USA.**
- ✚ High Discharge capacity of 1000 US GPM (3785 LPM) at 100 psi inlet pressure.
- ✚ Excellent Horizontal throw of 65 to 70 meter long and above
- ✚ Excellent Full Fog & Semi Fog Coverage.
- ✚ Low Expansion, so less loss of foam & more cooling effect on hot surface.
- ✚ Quick change over from jet to fog even during high operating pressure
- ✚ Easy maneuverability in horizontal and vertical plane
- ✚ Fully Stainless Steel Construction.
- ✚ Almost maintenance free
- ✚ Available In Fixed and Mobile Version
- ✚ Various Metallurgy Option

3. APPLICATION

The Monitor is highly effective with water and foam for fast knockdown of Fires at Oil & Gas Plants, Off-Shore & On Shore Platforms, Oil Refineries, Petroleum Storage Tanks & Depots, Chemical & Fertilizer Plants, Steel Plants, Power Plants, Ammunition Depots, Defense Stores, Naval Ships, Ships & Oil tankers Ports & Jetties Etc.

UL LISTED FIRE FOAM MONITOR

MODEL GGT SGR 1000

4. TECHNICAL SPECIFICATION

✚ Flow at 100 psi (7 bar) pressure	:	1000 US GPM (3785 LPM)
✚ Nozzle	:	Non-aspirating type
✚ Induction Type	:	SELF Type
✚ Induction Rate	:	3 % (As Per UL Guidelines)
✚ Foam Pick Up Tube	:	PVC 3 Mtr. with Fittings
✚ Monitor Elevation	:	+90° & - 30° Vertical
✚ Rotation	:	360° Horizontal.
✚ Water way size	:	100 NB
✚ Inlet Flange Size	:	4" NB 150# S.O.R.F Flange
✚ Hydrostatic Test Pressure (Monitor)	:	21 bar.
✚ Finish/ Paint	:	Fire red shade of Epoxy / Powder Coating.

5. MATERIAL OF CONSTRUCTION FOR MONITOR AND NOZZLE

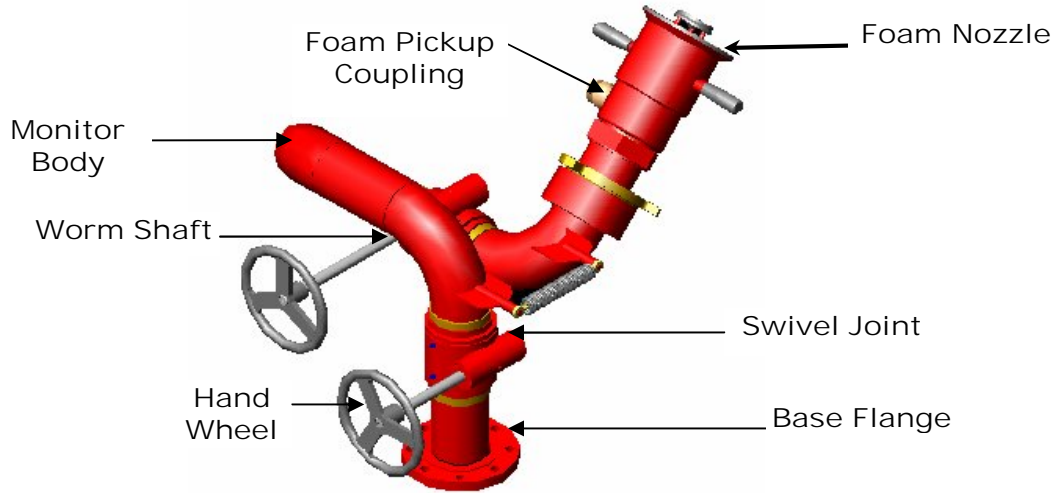

✚ Base Flange	:	SS 304
✚ Monitor Body	:	SS 304
✚ Swivel joint	:	SS 304 / Gun Metal / Bronze
✚ Worm Shaft	:	SS 304
✚ Hand Wheel	:	SS 304
✚ Neck Ring	:	SS 304
✚ Foam Nozzle	:	SS 304 / Gun Metal / Bronze / Aluminum

MONITOR ALSO AVAILABLE IN METALLURGY OF SS 316 FOR SPECIAL APPLICATION.

6. PERFORMANCE OF MONITOR AT 100 PSI (IN STILL AIR CONDITION)

a) Water jet at 30° from Horizontal plane	:	70 mtrs.
b) Foam jet at 30° from Horizontal plane	:	65 mtrs.
c) Fog jet at 30° from Horizontal plane	:	20 mtrs.

7. APPROVAL: UL LISTED WITH FOLLOWING FEATURES

a) Nozzle	:	Non Air Aspirating Nozzle
b) Monitor Solution Flow	:	1000 US GPM
c) Operating Pressure	:	100 PSI
d) Induction	:	By Nozzle having Self Induction