

UL LISTED FIRE FOAM MONITOR

MODEL GGT SGC 2000

1. GENERAL DESCRIPTION

The manually operated self-inducting non-aspirating Compact Foam Monitor fully made of Stainless Steel, capable of discharging 2000 US GPM (7570 LPM) at 100 psi inlet pressure over a range of 80 to 85 meters in horizontal direction. Foam proportioning 3 % is done with help of Foam Inductor placed within the Nozzle. The Foam Monitor has facility for converting Water / Foam jet to fog and vice-versa very quickly and easily, even during continuous operation. Foam Monitor is provided with self-locking swivel gear bearing for rotation in horizontal and vertical direction through hand wheel operation even under high operating pressures. A single fire fighter can manually operate the Foam Monitor with large flow & long-range capability. The monitor assembly is designed to withstand the nozzle reaction force experienced during the operation of jet / fog.

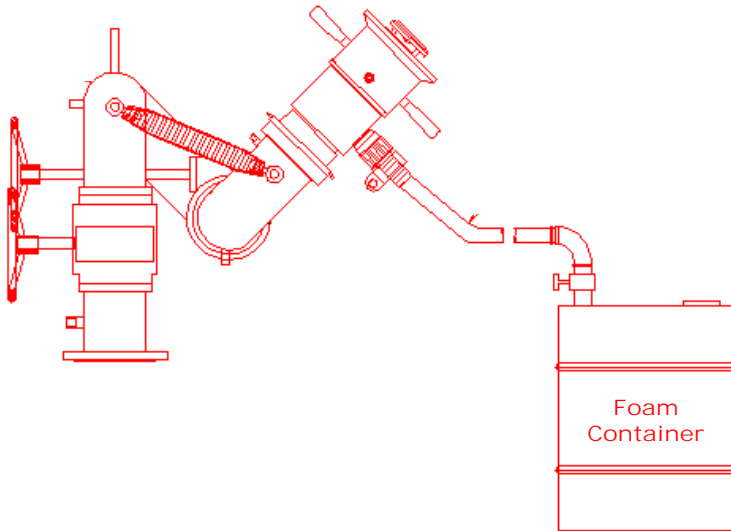
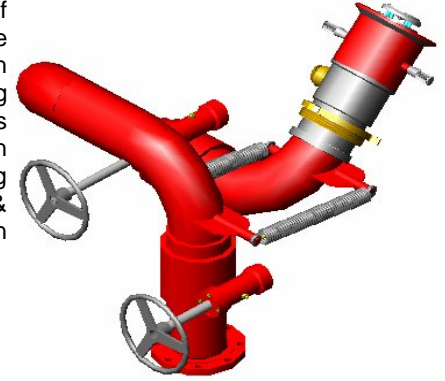

Jet & Fog Adjustment

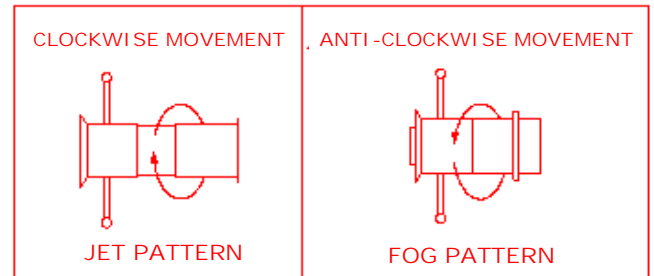

2. SALIENT FEATURES

- ✚ Certified and Approved by **(UL) Underwriters Laboratory USA.**
- ✚ High Discharge capacity of 2000 US GPM (7570 LPM) at 100 psi inlet pressure.
- ✚ Excellent Horizontal throw of 80 to 85 meter long and above.
- ✚ Excellent Full Fog & Semi Fog Coverage.
- ✚ Low Expansion, so less loss of foam & more cooling effect on hot surface.
- ✚ Quick change over from jet to fog even during high operating pressure.
- ✚ Very Compact in Construction and gives good flexibility of the operation while fire fighting.
- ✚ Easy maneuverability in horizontal and vertical plane.
- ✚ Fully Stainless Steel Construction.
- ✚ Almost maintenance free.
- ✚ Available In Fixed and Mobile Version.
- ✚ Various Metallurgy Options.

3. APPLICATION

The Monitor is highly effective with water and foam for fast knockdown of Fires at Oil & Gas Plants, Off-Shore & On Shore Platforms, Oil Refineries, Petroleum Storage Tanks & Depots, Chemical & Fertilizer Plants, Steel Plants, Power Plants, Ammunition Depots, Defense Stores, Naval Ships And Submarine, Ships & Oil tankers Ports & Jetties Etc.

UL LISTED FIRE FOAM MONITOR

MODEL GGT SGC 2000

4. TECHNICAL SPECIFICATION

⚡	Flow at 100 psi (7 bar) pressure	:	2000 US GPM (7570 LPM)
⚡	Nozzle	:	Non-aspirating type
⚡	Induction Type	:	SELF Type
⚡	Induction Rate	:	3 % (As Per UL Guidelines)
⚡	Foam Pick Up Tube	:	PVC 3 meter with Fittings
⚡	Monitor Elevation	:	+90° & - 30° Vertical
⚡	Rotation	:	360° Horizontal.
⚡	Water way size	:	150 NB
⚡	Inlet Flange Size	:	6" NB 150# S.O.R.F Flange
⚡	Hydrostatic Test Pressure (Monitor)	:	21 bar.
⚡	Finish/ Paint	:	Fire red shade of Epoxy / Powder Coating.

5. MATERIAL OF CONSTRUCTION FOR MONITOR AND NOZZLE

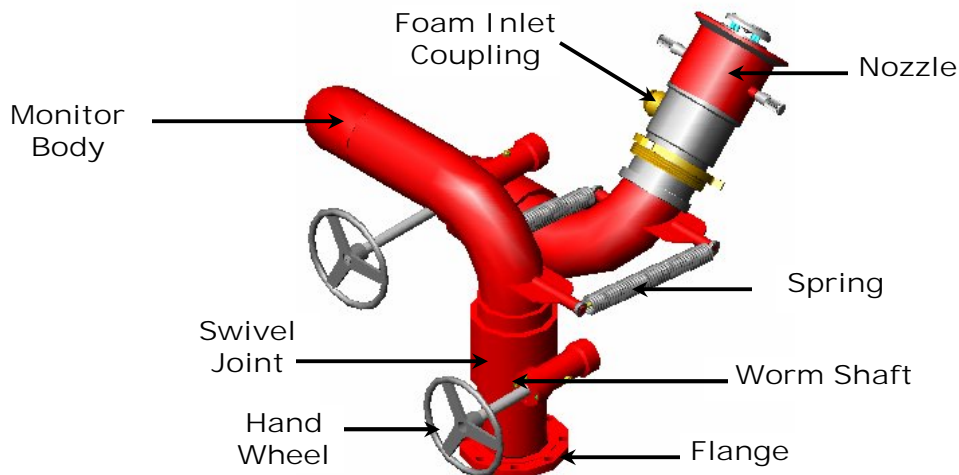

⚡	Base Flange	:	SS 304 / SS 316
⚡	Monitor Body	:	SS 304 / SS 316
⚡	Swivel joint	:	SS 304 / SS 316 Gun Metal / Bronze
⚡	Worm Shaft	:	SS 304 / SS 316
⚡	Hand Wheel	:	SS 304 / SS 316
⚡	Neck Ring	:	SS 304 / SS 316
⚡	Foam Nozzle	:	SS 304 / SS 316 / Gun Metal / Bronze / Aluminum
⚡	Lifting Hook	:	SS 304 / SS 316

MONITOR ALSO AVAILABLE IN METALLURGY OF SS 316 FOR SPECIAL APPLICATION.

6. PERFORMANCE OF MONITOR AT 100 PSI (IN STILL AIR CONDITION)

a)	Water jet at 30° from Horizontal plane	:	85 mtrs.
b)	Foam jet at 30° from Horizontal plane	:	80 mtrs.
c)	Fog jet at 30° from Horizontal plane	:	20 mtrs.

7. APPROVAL: UL LISTED WITH FOLLOWING FEATURES

a)	Nozzle	:	Non Air Aspirating Nozzle
b)	Monitor Solution Flow	:	2000 US GPM
c)	Operating Pressure	:	100 PSI
d)	Induction	:	By Nozzle having Self Induction